

Generalized Unsharp Masking Algorithm for Contrast And Sharpness

Bharathi¹, N Santosh², A Sonthosh³
^{1,2,3} ECE Dept, Sree Dattha Institute of Engineering & Science

ABSTRACT: In the applications like medical radiography enhancing movie features and observing the planets it is necessary to enhance the contrast and sharpness of an image. The model propose a generalized unsharp masking algorithm using the exploratory data model as a unified framework. The proposed algorithm is designed as to solve simultaneously enhancing contrast and sharpness by means of individual treatment of the model component and the residual, reducing the halo effect by means of an edge-preserving filter, solving the out of range problem by means of log ratio and tangent operations. Here is a new system called the tangent system which is based upon a specific bargeman divergence. Experimental results show that the proposed algorithm is able to significantly improve the contrast and sharpness of an image. Using this algorithm user can adjust the two parameters the contrast and sharpness to have desired output

Index Terms: Bregman divergence, exploratory data model, generalized linear system, image enhancement, unsharp masking.

I. INTRODUCTION

A digital gray image is a simple two dimensional matrix of numbers ranging from 0 to 255. These numbers represents different shades of gray. The number '0' represents pure black color and number '255' represents pure white color.

1.1 Image Enhancement

The aim of image enhancement is to improve the interpretability or perception of information in images for human viewers, or to provide 'better' input for other automated image processing techniques.

1.1.1 Brightness Control

If the digital image is of poor brightness, the objects in the image will not be visible clearly. It should be the case when the image is captured under low light conditions. To rectify this problem, we can further increase the brightness of the captured digital image and make the image more attractive. If we study the histogram of a low-brightness image, we will find that the most of the pixels lie in the left half of the gray value range. The brightness of a dark image can easily be increased by adding a constant to gray value of every pixel.

1.1.2 Contrast Stretching

This operation is much better for the image quality enhancement in comparison to brightness control. If low contrast image is resulted due to low light conditions, lack of dynamic range of the camera sensor, contrast stretching operation results in the good quality image. During the contrast stretching operation, we basically increase the dynamic range of the gray values. We can use many functions for contrast stretching, the piecewise transformation function is discussed here.

1.2 Digital Image Enhancement Techniques

Now-a-days digital images have enveloped the complete world. The digital cameras which are main source of digital images are widely available in the market in cheap ranges. Sometimes the image taken from a digital camera is not of quality and it required some enhancement. There exist many techniques that can enhance a digital image without spoiling it. First of all, let me tell you that the enhancement methods can broadly be divided in to the following two categories:

1. Spatial Domain Methods 2. Frequency Domain Methods

1.3 Spatial domain methods

The value of a pixel with coordinates (x, y) in the enhanced image \hat{F} is the result of performing some operation on the pixels in the neighborhoods of (x, y) in the input image, F . Neighborhoods can be any shape, but usually they are rectangular.

1.3.1 Grey scale manipulation

The simplest form of operation is when the operator T only acts on a 1×1 pixel neighborhood in the input image, that is $\hat{F}(x, y)$ only depends on the value of F at (x, y) . This is a grey scale transformation or mapping. The simplest case is thresholding where the intensity profile is replaced by a step function, active at a chosen threshold value. In this case any pixel with a grey level below the threshold in the input image gets mapped to 0 in the output image. Other pixels are mapped to 255.

1.3.2 Image Smoothing

The aim of image smoothing is to diminish the effects of camera noise, spurious pixel values, missing pixel values etc. There are many different techniques for image smoothing; we will consider neighborhood averaging and edge-preserving smoothing.

1.3.2.1 Neighborhood Averaging

Each point in the smoothed image, $f(x, y)$ is obtained from the average pixel value in a neighborhood of (x, y) in the input image. For example, if we use a 3×3 neighborhood around each pixel we would use the mask Each pixel value is multiplied by $1/9$, summed, and then the result placed in the output image. This mask is successively moved across the image until every pixel has been covered. That is, the image is convolved with this smoothing mask (also known as a spatial filter or kernel). However, one usually expects the value of a pixel to be more closely related to the values of pixels close to it than to those further away.

1.3.2.2 Edge preserving smoothing

Neighborhood averaging or Gaussian smoothing will tend to blur edges because the high frequencies in the image are attenuated. An alternative approach is to use *median filtering*. Here we set the grey level to be the median of the pixel values in the neighborhood of that pixel. The median m of a set of values is such that half the values in the set are less than m and half are greater.

1.3.3 Image sharpening

The main aim in image sharpening is to highlight fine detail in the image, or to enhance detail that has been blurred (perhaps due to noise or other effects, such as motion). With image sharpening, we want to enhance the high-frequency components; this implies a spatial filter shape that has a high positive component at the centre.

1.4 Frequency domain methods

Image enhancement in the frequency domain is straightforward. We simply compute the Fourier transform of the image to be enhanced, multiply the result by a filter (rather than convolve in the spatial domain), and take the inverse transform to produce the enhanced image. The idea of blurring an image by reducing its high frequency components, or sharpening an image by increasing the magnitude of its high frequency components is intuitively easy to understand

II. CLASSICAL UNSHARP MASKING

2.1 Introduction

Proper sharpening is a bit like black magic. We can't really sharpen an image any more than it already is. If it wasn't sharp when captured, there's nowhere the information needed can come from later on. What we can do is create the *illusion* of sharpness by exaggerating contrast along edges in the image. This added contrast makes the edges stand out more, making them appear sharper.

Unsharp masking (UM) is an image manipulation technique, often available in digital image processing software. The "unsharp" of the name derives from the fact that the technique uses a blurred, or "unsharp," positive to create a "mask" of the original image. The unsharped mask is then combined with the negative, creating the illusion that the resulting image is sharper than the original. From a standpoint, an unsharp mask is generally a linear or nonlinear filter that amplifies high-frequency components.

2.2 Unsharp masking process

The sharpening process works by utilizing a slightly blurred version of the original image. This is then subtracted away from the original to detect the presence of edges, creating the unsharp mask (effectively a high-pass filter). Contrast is then selectively increased along these edges using this mask, leaving behind a sharper final image.

2.3 Un sharp masking algorithm

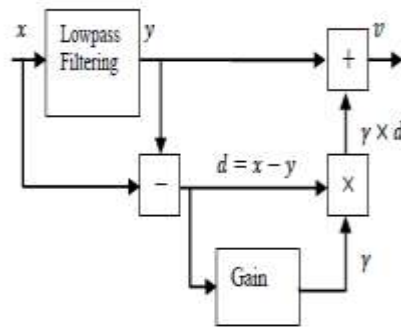

Fig.2.2: Block diagram of classical unsharp masking algorithm

The classical unsharp masking algorithm can be described by the equation $V = y + \gamma(x - y)$: where x is the input image, y , is the result of a linear low-pass filter, and the gain γ ($\gamma > 0$) is a real scaling factor. The signal $d = x - y$ is usually amplified ($\gamma > 1$) to increase the sharpness. However, the signal d contains 1) details of the image, 2) noise, and 3) over-shoots and under-shoots in areas of sharp edges due to the smoothing of edges. While the enhancement of noise is clearly undesirable, the enhancement of the undershoot and overshoot creates the visually unpleasant halo effect. Ideally, the algorithm should only enhance the image details.

This requires that the filter is not sensitive to noise and does not smooth sharp edges. These issues have been studied by many researchers. For example, the cubic filter and the edge-preserving filters have been used to replace the linear low-pass filter. The former is less sensitive to noise and the latter does not smooth sharp edges. Adaptive gain control has also been studied. Contrast is a basic perceptual attribute of an image. It is difficult to see the details in a low contrast image. Adaptive histogram equalization is frequently used for contrast enhancement.

2.3.1 Halo effect

This tiny image is a simple three tone graphic image containing two contrast edges, shown unsharpened on the left, and sharpened with the Unsharp Mask on the right. It is also shown greatly enlarged about 10X so the pixels can be seen well. Remember about anti-aliasing blending the edges with intermediate tones (usually only on angled or jagged edges). Unsharp Mask is the opposite, it involves making the pixels on the light side of the edge even lighter, and making the pixels on the dark side of the edge even darker, as shown, to increase edge contrast. This then shows the edge better, therefore we perceive the edge to be sharper. Give this a little thought, because the same effect happens to all of the edges in your photograph with the Unsharp Mask. This image also demonstrates the halo effect due to too much sharpening.

2.4 Photographic unsharp masking

The technique was first used in Germany in the 1930s as a way of increasing the acutance, or apparent sharpness, of photographic images. In the photographic process, a large-format glass plate negative is contact-copied onto a low contrast film or plate to create a positive. However, the positive copy is made with the copy material in contact with the *back* of the original, rather than emulsion-to-emulsion, so it is blurred. After processing this blurred positive is replaced in contact with the back of the original negative. When light is passed through negative and in-register positive (in an enlarger for example), the positive partially cancels some of the information in the negative. Because the positive has been intentionally blurred, only the low frequency (blurred) information is cancelled. In addition, the mask effectively reduces the dynamic range of the original negative. Thus, if the resulting enlarged image is recorded on contrasty photographic paper, the partial cancellation emphasizes the high frequency (fine detail) information in the original, without loss of highlight or shadow detail. The resulting print appears sharper than one made without the unsharp mask: its acutance is increased.

In the photographic procedure, the amount of blurring can be controlled by changing the softness or hardness (from point source to fully diffuse) of the light source used for the initial unsharp mask exposure, while the strength of the effect can be controlled by changing the contrast and density (i.e., exposure and development) of the unsharp mask.

In traditional photography, unsharp masking is usually used on monochrome materials; special panchromatic soft-working black and white films have been available for masking photographic color transparencies. This has been especially useful to control the density range of a transparency intended for photomechanical reproduction.

2.5 Digital unsharp masking

The same differencing principle is used in the unsharp-masking tool in many digital-imaging software packages, such as Adobe Photoshop and GIMP. The software applies a Gaussian blur to a copy of the original image and then compares it to the original. If the difference is greater than a user-specified threshold setting, the images are (in effect) subtracted. The threshold control constrains sharpening to image elements that differ from each other above a certain size threshold, so that sharpening of small image details, such as photographic grain, can be suppressed.

Digital unsharp masking is a flexible and powerful way to increase sharpness, especially in scanned images. However, it is easy to create unwanted and conspicuous edge effects, or increase image noise. On the other hand, these effects can be used creatively, especially if a single channel of an RGB or Lab image is sharpened. Undesired effects can be reduced by using a mask particularly one created by edge detection to only apply sharpening to desired regions, sometimes termed "smart sharpen".

2.5.1 Local contrast enhancement

Unsharp masking may also be used with a large radius and a small amount (such as 30–100 pixel radius and 5–20% amount) which yields increased local contrast, a technique termed local contrast enhancement. USM can increase either sharpness or (local) contrast because these are both forms of increasing differences between values, increasing slope – sharpness referring to very small-scale (high frequency) differences, and contrast referring to larger scale (low frequency) differences. More powerful techniques for improving tonality are referred to as tone mapping.

2.5.2 Comparison with deconvolution

In image processing, deconvolution is the process of approximately inverting the process that caused an image to be blurred. Specifically, unsharp masking is a simple linear image operation a convolution by a kernel that is the Dirac delta minus a Gaussian blur kernel. Deconvolution, on the other hand, is generally considered an ill-posed inverse problem that is best solved by nonlinear approaches. While unsharp masking increases the apparent sharpness of an image in ignorance of the manner in which the image was acquired, deconvolution increases the apparent sharpness of an image, but based on information describing some of the likely origins of the distortions in the light path used in capturing the image; it may therefore sometimes be preferred, where the cost in preparation time and per image computation time are offset by the increase in image clarity.

III. GENERALIZED LINEAR SYSTEM

3.1 Introduction

Marr has pointed out that to develop an effective computer vision technique one must consider: 1) why the particular operations are used, 2) how the signal can be represented, 3) what implementation structure can be used. Myers has also pointed out that there is no reason to persist with particular operations such as the usual addition and multiplication, if via abstract analysis, more easily implemented and more generalized or abstract versions of mathematical operations can be created for digital signal processing. Consequently, abstract analysis may show new ways of creating systems with desirable properties. Following these ideas, the generalized linear system, shown in Fig. 3.1, is developed.

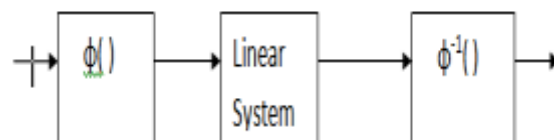

Fig 3.1: Block diagram of a generalized linear system, where $\phi()$ is usually a nonlinear function.

The generalized addition and scalar multiplication operations denoted by \oplus and \otimes are defined as follows:

$$x \oplus y = \phi^{-1} [\phi(x) + \phi(y)] \dots\dots\dots (3.1) \ \&$$

$$\alpha \otimes x = \phi^{-1} [\alpha \phi(x)] \dots\dots\dots (3.2)$$

Where x and y are signal samples, α is usually a real scalar, and ϕ is a nonlinear function.

The log-ratio approach was proposed to systematically tackle the out of range problem in image restoration. The log ratio can be understood from a generalized linear system point of view, since its operations are implicitly defined by using equations. A remarkable property of the log-ratio approach is that the gray scale set is closed under the new operations.

Deng used the log-ratio in a generalized linear system context for image enhancement. In their review papers, Cahill and Deng and Pinoli compared the log-ratio with other generalized linear system-based image processing techniques such as the multiplicative homomorphic filters and the logarithmic image processing (LIP) model.

Comparative study of the multiplicative homomorphic image processing (MHIP), the log-ratio image processing (LRIP) and the logarithmic image processing (LIP). These three image processing approaches are based on abstract linear mathematics and provide specific operations and structures that have opened up new pathways to the development of image processing techniques. The MHIP approach was designed for the processing of multiplied images, the LRIP approach was introduced to overcome the out-of-range problem associated with many image processing techniques, while the LIP approach was developed for the processing of images valued in a bounded intensity range. First, it is claimed that an image processing framework must be physically relevant, mathematically consistent, computationally tractable and practically fruitful. It is also pointed out that the classical linear image processing (CLIP) is not adapted to non-linear and/or bounded range images or imaging systems, such as transmitted light images, practical digital images or the human brightness perception system. Then, the importance and usefulness of several mathematical fields, such as abstract linear algebra and abstract analysis, for image representation and processing within such image settings are discussed. Third, the MHIP, LRIP and LIP approaches are presented, focusing on their distinctive ideas, structures and properties for image representation and processing, rather than an in-depth review.

3.2 Image Model and Generalized Unsharp Masking

A well known idea in exploratory data analysis is to decompose a signal into two parts. One part fits a particular model, while the other part is the residual. In Turkey's own words the data model is: "Data=fit PLUS residuals". From this point of view, the output of the filtering process, denoted $y = f(x)$, can be regarded as the part of the image that fits the model. Thus, we can represent an image using the generalized operations (not limited to the log-ratio operations) as follows:

$$x = y \oplus d \quad (3.3)$$

Where d is called the detail signal. The detail signal is defined as $d = x \ominus y$ where \ominus is the generalized subtraction operation. Although this model is simple, it provides us with a unified framework to study unsharp masking algorithms. A general form of the unsharp masking algorithm can be written as $v = h(y) \oplus g(d)$ (3.4)

Where v is output of the algorithm and both $h(y)$ and $g(d)$ could be linear or nonlinear functions. This model explicitly states that the part of the image being sharpened is the model residual. This will force the algorithm developer to carefully select an appropriate model and avoid models such as linear filters. In addition, this model permits the incorporation of contrast enhancement by means of a suitable processing function $h(y)$ such as adaptive histogram equalization. As such, the generalized algorithm can enhance the overall contrast and sharpness of the image.

2.3 Definitions and Properties of Log-Ratio Operations

2.3.1 Nonlinear Function

We consider the pixel gray scale of an image $x \in (0,1)$. For an N -bit image we can first add a very small positive constant to the pixel gray value then scale it by 2^{-N} such that it is in the range $(0,1)$. The nonlinear function is defined as follows:

$$\phi(x) = \log \frac{1-x}{x} \quad (3.5)$$

To simplify notation, we define the ratio of the negative image to the original image as follows:

$$X = \psi(x) = \frac{1-x}{x} \quad (3.6)$$

1. Addition and Scalar Multiplication:

Using (3.1), the addition of two gray scales x_1 and x_2 is defined as

$$x_1 \oplus x_2 = \frac{1}{1+\psi(x_1)\psi(x_2)} = \frac{1}{1+x_1x_2} \quad (3.7)$$

Where $X_1 = \psi(x_1)$ and $X_2 = \psi(x_2)$

The multiplication of a gray scale x by a real scalar is defined by α ($-\infty < \alpha < \infty$) using (3.2) as follows:

$$\alpha \otimes x = \frac{1}{1+x^\alpha} \quad (3.8)$$

This operation is called scalar multiplication which is a terminology derived from a vector space point of view. We can define a new zero gray scale, denoted, as follows:

$$e \oplus x = x \quad (3.9)$$

It is easy to show that $e=1/2$. This definition is consistent with the definition of scalar multiplication in that $0 \otimes x = 1/2$. As a result, we can regard the intervals $(0, \frac{1}{2})$ and $(\frac{1}{2}, 1)$ as the new definitions of negative and positive numbers, respectively. The absolute value, denoted by x_0 , can be defined in a similar way as the absolute value of the real number as follows:

$$x_0 = \begin{cases} x, & \frac{1}{2} \leq x < 1 \\ 1 - x, & 0 < x < \frac{1}{2} \end{cases} \quad (3.10)$$

2. Negative Image and Subtraction Operation:

A natural extension is to define the negative of the gray scale. Although this can be defined in a similar way as those described in (3.7) and (3.8), we take another approach to gain deeper insights into the operation. The negative of the gray scale, denoted by $\ominus x$, is obtained by solving

$$x \oplus x' = 1/2 \quad (3.11)$$

The result is $x' = 1 - x$ which is consistent with the classical definition of the negative image. Indeed, this definition is also consistent with the scalar multiplication in that $-1 \otimes x = 1 - x$. Following the notation of the classical definition of negative numbers, we can define the negative gray scale as $\ominus x = (-1) \otimes x$. We can now define the subtraction operation using the addition operation defined in (8) as follows:

$$\begin{aligned} x_1 \ominus x_2 &= x_1 \oplus (\ominus x_2) \quad (3.12) \\ &= \frac{1}{\psi(x_1)\psi(\ominus x_2)+1} \\ &= \frac{1}{x_1 x_2^{-1} + 1} \end{aligned}$$

Where we can easily see that $\varphi(\ominus x_2) = 1/\varphi(x_2) = X_2^{-1}$. Using the definition of the negative gray scale, we also have a clear understanding of the scalar multiplication for $\alpha < 0$.

$$\begin{aligned} y &= \alpha \otimes x \\ &= (-1) \otimes (|\alpha| \otimes x) \\ &= 1 - |\alpha| \otimes x \quad (3.13) \end{aligned}$$

Here we have used $\alpha = (-1)x|\alpha|$ and the distributive law for two real scalars α and β .

$$(\alpha \times \beta) \otimes x = \alpha \otimes (\beta \otimes x) \quad (3.14)$$

3.2.2 Properties

What would be the result if we add a constant α ($0 < \alpha < 1$) to an image x such that $Y = x \oplus \alpha$ since the zero is $1/2$, we only consider two cases: $0 < \alpha < 1/2$ and $1/2 \leq \alpha < 1$. The order relations for the addition operation are shown in Table.3.1.

Table.3.1: Order relations of the log-ratio addition

	$0 < \alpha < 1/2$	$1/2 < \alpha < 1$
$0 < x < 1/2$	$0 < x \oplus \alpha < \min(x, \alpha)$	$x < x \oplus \alpha < \alpha$
$1/2 < x < 1$	$\alpha < x \oplus \alpha < x$	$\min(x, \alpha) < x \oplus \alpha < 1$

When α is fixed, the result y is a function of x . In the top row of Fig.3.2, we show several cases in order to visualize the effects. We can see that when $\alpha < \frac{1}{2}$ the dynamic range of the higher gray scale values are expanded at the cost of compressing that of lower gray scale values. When $\alpha > \frac{1}{2}$, the effect is just the reverse of that of the previous case. Therefore, the operation $y = x \oplus \alpha$ has a similar effect as that of the gamma correction operation defined as x^γ . For example, to enhance the dark areas of the cameraman image (8-bit/pixel), we could use $\alpha = \frac{196}{256}$ for the log-ratio and $\gamma = 0.65$ for gamma correction. The results are shown in Fig.3.3.

For the subtraction operation, we can derive similar results as those of the addition operation by considering $x_1 \ominus x_2 = x_1 \oplus (1 - x_2)$. For scalar multiplication $y = \alpha \otimes x$, we already know three special cases when $\alpha = -1, 0, 1$. In Table.3.2, we list the order relations for $\alpha > 0$. The corresponding relationships for the case of $\alpha < 0$ can be easily derived by using (3.13). In the bottom row of Fig.3.2, we show several cases which help us to understand the characteristics of the scalar multiplication. We can see from the figure that when $0 < \alpha < 1$, the dynamic ranges of the gray scale values close to 0 or 1 are expanded and that near the middle (1/2) is compressed. When $\alpha > 1$, the dynamic range of the gray scale values near 1/2 is expanded and those near 0 or 1 are compressed. In fact, when α is set a large number, say 10, the effect is just like a thresholding process, i.e. $y \rightarrow 0$, for $x < \frac{1}{2}$ and $y \rightarrow 1$ for $x > 1/2$.

Table.3.2: Order relations of the log-ratio addition

	$0 < \alpha < 1$	$\alpha > 1$
$0 < x < 1/2$	$\alpha \otimes x > x$	$\alpha \otimes x < x$
$1/2 < x < 1$	$\alpha \otimes x < x$	$\alpha \otimes x > x$

3.2.3 Computations

Computations can be directly performed using the new operations. For example, for any real numbers α_1 and α_2 , the weighted summation is given by

$$(\alpha_1 \otimes x_1) \oplus (\alpha_2 \otimes x_2) = \frac{1}{x_1^{\alpha_1} x_2^{\alpha_2} + 1} \quad (3.15)$$

The subtraction operation can be regarded as a weighted summation with $\alpha_1 = 1$ and $\alpha_2 = -1$. In image processing the classical weighted average of a block of pixels $\{x_n\}_{n=1:N}$ is given by

$$u_{WA} = \sum_{n=1}^N \alpha_n x_n \dots \quad (3.16)$$

Where $\sum_{n=1}^N \alpha_n = 1$. similarly, the generalized weighted averaging operation is defined as

$$y = (\alpha_1 \otimes x_1) \oplus (\alpha_2 \otimes x_2) \dots \dots \oplus (\alpha_N \otimes x_N) \quad (3.17)$$

$$= \frac{G}{G + \bar{G}}$$

Where $G = (\prod x_n^{\alpha_n})^{1/N}$ and $\bar{G} = (\prod (1 - x_n)^{\alpha_n})^{1/N}$ are the weighted geometric means of the original and the negative images, respectively. An indirect computational method is through the nonlinear function (3.5). For example, the generalized weighted average can be calculated as follows:

$$y = \phi^{-1}\{\phi[(\alpha_1 \otimes x_1) \oplus (\alpha_2 \otimes x_2) \dots \dots \oplus (\alpha_N \otimes x_N)]\} \quad (3.18)$$

$$= \phi^{-1}\{\sum_{n=1}^N \alpha_n \phi(x_n)\}$$

Although this computational method may be more efficient than the direct method in certain applications, the direct method provides us more insights into the operation. For example clearly shows the connection between the generalized weighted average and the geometric mean.

3.3 Bregman Divergence

The **Bregman divergence** or **Bregman distance** is similar to a metric, but does not satisfy the triangle inequality or symmetry. There are two ways in which Bregman divergences are important. Firstly, they generalize squared Euclidean distance to a class of distances that all share similar properties. Secondly, they bear a strong connection to exponential families of distributions; as has been shown by (Banerjee et al. 2005), there is a bijection between regular exponential families and regular Bregman divergences.

3.3.1 Definition

Let $F : \Delta \rightarrow \mathbb{R}$ be a continuously-differentiable real-valued and strictly convex function defined on a closed convex set Δ . The Bregman distance associated with F for points $p, q \in \Delta$ is:

$$B_F(p||q) = F(p) - F(q) - \langle \nabla F(q), (p - q) \rangle \quad (3.19)$$

Intuitively this can be thought of as the difference between the value of F at point p and the value of the first-order Taylor expansion of F around point q evaluated at point p .

3.3.2 Properties

- **Non-negativity:** $B_F(p||q) \geq 0$ for all p, q . This is a consequence of the convexity of F .
- **Convexity:** $B_F(p||q)$ is convex in its first argument, but not necessarily in the second argument.
- **Linearity:** If we think of the Bregman distance as an operator on the function F , then it is linear with respect to non-negative coefficients. In other words, for F_1, F_2 strictly convex and differentiable, and $\lambda > 0$,

$$B_{F_1 + \lambda F_2}(p||q) = B_{F_1}(p||q) + \lambda B_{F_2}(p||q) \quad (3.20)$$
- **Duality:** The function F has a convex conjugate F^* . The Bregman distance defined with respect to F^* has an interesting relationship to $B_F(p||q)$

$$B_{F^*}(p^*||q^*) = B_F(q||p) \quad (3.21)$$

Here, $p^* = \nabla F(p)$ is the dual point corresponding to p

A key result about Bregman divergences is that, given a random vector, the mean vector minimizes the expected Bregman divergence from the random vector.

IV. PROPOSED ALGORITHM

In the proposed algorithm, the user can adjust the two parameters controlling the contrast and sharpness to produce the desired results. This makes the proposed algorithm practically useful. These related works include unsharp masking and its variants, histogram equalization, retinex and dehazing algorithms, and generalized linear systems. It has been recently studied by many researchers for manipulating contrast, sharpness, and dynamic range of digital images. The retinex algorithm is based upon the imaging model in which the observed image is formed by the product of scene reflectance and illuminance. The task is to estimate the reflectance from the observation. Many algorithms use the assumption that the illuminance is spatially smooth. Enhancement of contrast and sharpness of an image is required in many applications. Unsharp masking is a classical tool for sharpness enhancement. We propose a generalized unsharp masking algorithm using the exploratory data model as a unified framework.

The proposed algorithm is designed to address three issues: 1) Simultaneously enhancing contrast and sharpness by means of individual treatment of the model component and the residual. 2) Reducing the halo effect by means of an edge-preserving filter. 3) Solving the out-of-range problem by means of log-ratio and tangent operations. Block diagram of Generalized unsharp masking algorithm shown in Fig.4.1, is based upon the previous image model and generalizes the classical unsharp masking algorithm by addressing issues stated in that algorithm.

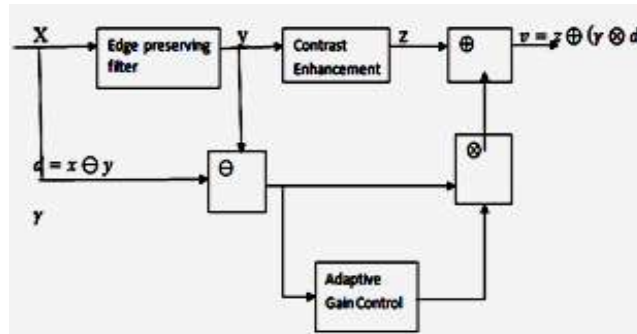

Fig.4.1: Block diagram of the proposed generalized unsharp masking algorithm

This algorithm address the issue of the halo effect by using an edge-preserving filter the IMF to generate the signal. The choice of the IMF is due to its relative simplicity and well studied properties such as the root signals. Other more advanced edge preserving filters such as the nonlocal means filter and wavelet-based denoising filters can also be used. This address the issue of the need for a careful rescaling process by using new operations defined according to the log-ratio and new generalized linear system. Since the gray scale set is closed under these new operations (addition \oplus and scalar multiplication \otimes formally defined), the out-of-range problem is systematically solved and no rescaling is needed. This algorithm address the issue of contrast enhancement and sharpening by using two different processes. The image y is processed by adaptive histogram equalization and the output is called $h(y)$. The detail image is processed by $g(d) = \gamma(d) \otimes d$ where $\gamma(d)$ is the adaptive gain and is a function of the amplitude of the detail signal. The final output of the algorithm is then given by

$$v = h(y) \oplus [\gamma(d) \otimes d] \tag{3.5}$$

We can see that the proposed algorithm is a generalization of the classical unsharp masking algorithm in several ways which are summarized in Table 4.1. In the following, we present details of the new operations and enhancement of the two images y and d .

Table.4.1: Comparison of classical unsharp masking with generalized unsharp masking

	y	d	$h(y)$	$g(d)$	Output v	Re-scale
UM	LPF	$x-y$	Y	$\gamma(d) \otimes d$	$Y \oplus \gamma(d) \otimes d$	Yes
GUM	EPF	$x \ominus y$	ACE		$h(y) \oplus \gamma(d) \otimes d$	No

we first define the new operations using the generalized linear system approach. We use (3.1) and (3.2) to simplify presentation. Note that these operations can be defined from the vector space point of view which is similar to that of the development of the LIP model . We then study properties of these new operations from an image processing perspective. We show the connection between the log-ratio, generalized linear systems and the Bregman divergence. As a result, we not only show novel interpretations of two existing generalized linear systems, but also develop a new system.

4.1 Dealing with Color Images

We first convert a color image from the RGB color space to the HSI or the LAB color space. The chrominance components such as the H and S components are not processed. After the luminance component is processed, the inverse conversion is performed. An enhanced color image in its RGB color space is obtained. The rationale for only processing the luminance component is to avoid a potential problem of altering the white balance of the image when the RGB components are processed individually.

4.1.1 RGB color model

The RGB color model is an additive color model in which red, green, and blue light are added together in various ways to reproduce a broad array of colors. The name of the model comes from the initials of the three additive primary colors, red, green, and blue. The main purpose of the RGB color model is for the sensing, representation, and display of images in electronic systems, such as televisions and computers, though it has also been used in conventional photography. Before the electronic age, the RGB color model already had a solid theory behind it, based in human perception of colors.

4.1.2 HSI color model

The HSI color space is very important and attractive color model for image processing applications because it represents color s similarly how the human eye senses colors. The HSI color model represents every color with three components: hue(H), saturation(S), intensity(I). "Hue" is what an artist refers to as "pigment"; it is what we think of as "color" -- yellow, orange, cyan and magenta are examples of different hues. An artist usually starts with a highly saturated (i.e., pure), and intense (i.e., bright) pigment, and then adds some white to reduce its saturation and some black to reduce its intensity. Red and Pink are two different "saturation" of the same hue, Red. The HSI model is useful when processing images to compare two colors, or for changing a color from one to another. For example, changing a value from Cyan to Magenta is more easily accomplished in an HSI model; only the H value needs to be changed (from 180 to 300). Making the same change in an RGB view is less intuitive; since you must know the correct amounts of Red, Green and Blue needed to create Magenta. The HSI model is also a more useful model for evaluating or measuring an object's color characteristics, such as the "redness" of a berry or the "yellowness" of an autumn leaf.

4.2 Edge preserving filter

Image de-noising is an vital image processing task i.e. as a process itself as well as a component in other processes. There are many ways to de-noise an image or a set of data and methods exists. The important property of a good image de- noising model is that it should completely remove noise as far as possible as well as preserve edges. Traditionally, there are two types of models i.e. linear model and non-linear model. Generally, linear models are used. The benefits of linear noise removing models is the speed and the limitations of the linear models is, the models are not able to preserve edges of the images in a efficient manner i.e the edges, which are recognized as discontinuities in the image, are smeared out. On the other hand, Non-linear models can handle edges in a much better way than linear models.

4.2.1 Image Noise

Image noise is the random variation of brightness or color information in images produced by the sensor and circuitry of a scanner or digital camera. Image noise can also originate in film grain and in the unavoidable shot noise of an ideal photon detector. Image noise is generally regarded as an undesirable by-product of image capture. Although these unwanted fluctuations became known as "noise" by analogy with unwanted sound they are inaudible and such as dithering. The types of Noise are following:-

- Amplifier noise (Gaussian noise)
- Salt-and-pepper noise
- Shot noise (Poisson noise)
- Speckle noise

Amplifier noise

The standard model of amplifier noise is additive, Gaussian, independent at each pixel and independent of the signal intensity. In color cameras where more amplification is used in the blue color channel than in the green or red channel, there can be more noise in the blue channel .Amplifier noise is a major part of the "read noise" of an image sensor, that is, of the constant noise level in dark areas of the image.

Salt-and-pepper noise

An image containing salt-and-pepper noise will have dark pixels in bright regions and bright pixels in dark regions. This type of noise can be caused by dead pixels, analog-to-digital converter errors, bit errors in transmission, etc. This can be eliminated in large part by using dark frame subtraction and by interpolating around dark/bright pixels.

Shot noise

Poisson noise or shot noise is a type of electronic noise that occurs when the finite number of

particles that carry energy, such as electrons in an electronic circuit or photons in an optical device, is small enough to give rise to detectable statistical fluctuations in a measurement.

Speckle noise

Speckle noise is a granular noise that inherently exists in and degrades the quality of the active radar and synthetic aperture radar (SAR) images. Speckle noise in conventional radar results from random fluctuations in the return signal from an object that is no bigger than a single image-processing element. It increases the mean grey level of a local area. Speckle noise in SAR is generally more serious, causing difficulties for image interpretation. It is caused by coherent processing of backscattered signals from multiple distributed targets. In SAR oceanography, for example, speckle noise is caused by signals from elementary scatters, the gravity-capillary ripples, and manifests as a pedestal image, beneath the image of the sea waves.

4.2.2 Median filter

The Median filter is a nonlinear digital filtering technique, often used to remove noise. Such noise reduction is a typical pre-processing step to improve the results of later processing (for example, edge detection on an image). Median filtering is very widely used in digital image processing because under certain conditions; it preserves edges whilst removing noise. The main idea of the median filter is to run through the signal entry by entry, replacing each entry with the median of neighboring entries. Note that if the window has an odd number of entries, then the median is simple to define: it is just the middle value after all the entries in the window are sorted numerically.

4.2.3 The Root Signal and the Detail Signal

Let us denote the median filtering operation as a function $y = f(x)$ which maps the input to the output. An IMF operation can be represented as: $y_{k+1} = f(y_k)$ where $k=0,1,2,\dots$ is the iteration index $y_0 = x$ and The signal y_n is usually called the root signal of the filtering process if $y_{n+1} = y_n$. It is convenient to define a root signal as y_n follows

$$n = \min k, \text{ subject to } H(y_k, y_{k+1}) < \delta \tag{4.8}$$

Where $H(y_k, y_{k+1})$ is a suitable measure of the difference between the two images and is a user defined threshold. For natural images, it is usually the case that the mean squared difference, defined as $H(y_k, y_{k+1}) = (1/N) \|y_k - y_{k+1}\|_2^2$ (N is the number of pixels), is a monotonic decreasing function of k. It can be easily seen that the definition of the root signal depends upon the threshold. For example, it is possible to set a large value δ such that y_1 is the root signal. Indeed, after about five iterations $k \geq 5$ the difference $H(y_k, y_{k+1})$ changes δ only very slightly. As such, we can regard y_4 or y_5 as the root signal. Of course, the number of iterations, the size and the shape of the filter mask has certain impacts on the root signal. The properties of the root signal have been extensively studied. Here we use an example to illustrate the advantage of the proposed algorithm over the classical unsharp masking algorithm.

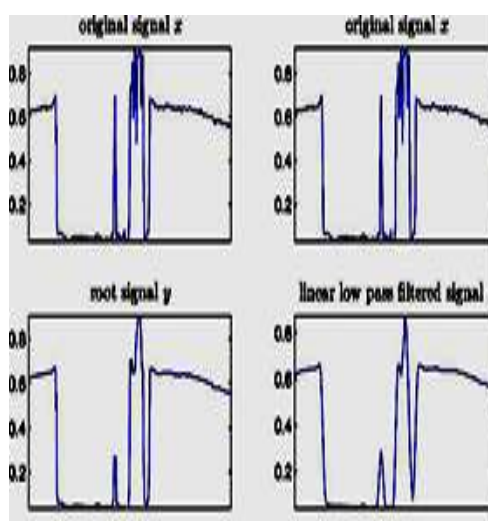

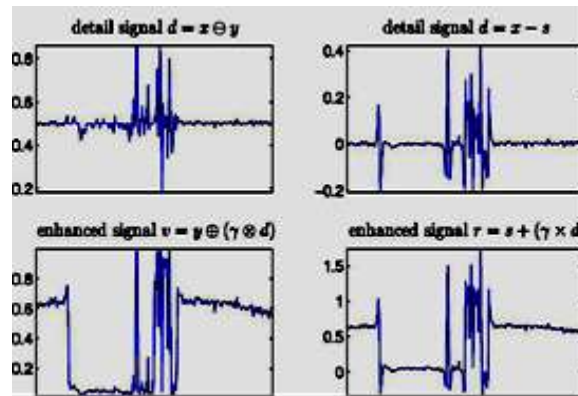

Fig.4.2:Illustration of the difference between the proposed generalized unsharp masking algorithm (left panel) and the classical unsharp masking algorithm (right panel).

4.3 Adaptive Gain Control

We know that to enhance the detail signal the gain must be greater than one. Using a universal gain for the whole image does not lead to good results, because to enhance the small details a relatively large gain is required. However, a large gain can lead to the saturation of the detailed signal whose values are larger than a certain threshold. Saturation is undesirable because different amplitudes of the detail signal are mapped to the same amplitude of either 1 or 0. This leads to loss of information. Therefore, the gain must be adaptively controlled. In the following, we only describe the gain control algorithm for using with the log-ratio operations. Similar algorithm can be easily developed for using with the tangent operations. To Control the gain; we first perform a linear mapping of the detail signal d to a new signal c

$$c = 2d - 1 \tag{4.9}$$

Such that the dynamic range of c is $(-1, 1)$. A simple idea is to set the gain as a function of the signal c and to gradually decrease the gain from its maximum value γ_{MAX} when $|c| < T$ to its minimum γ_{MIN} value when $|c| \rightarrow 1$. More specifically, we propose the following adaptive gain control function

$$\gamma(c) = \alpha + \beta \exp(-|c|^\eta) \tag{4.10}$$

Where η is a parameter that controls the rate of decreasing. The two parameters α and β are obtained by solving the equations: $\gamma(0) = \gamma_{MAX}$ and $\gamma(1) = \gamma_{MIN}$. For a fixed η , we can easily determine the two parameters as follows:

$$\beta = (\gamma_{MAX} - \gamma_{MIN}) / (1 - e^{-1}) \tag{4.11}$$

And

$$\alpha = \gamma_{MAX} - \beta \tag{4.12}$$

Although both γ_{MAX} and γ_{MIN} could be chosen based upon each individual image processing task, in general it is reasonable to set $\gamma_{MIN} = 1$. This setting follows the intuition that when the amplitude of the detailed signal is large enough, it does not need further amplification. For example, we can see that

$$\lim_{|d| \rightarrow 1} \gamma \otimes d = \lim_{|d| \rightarrow 1} \frac{1}{(1 + \gamma(1-d)/d)} = 1 \tag{4.13}$$

As such, the scalar multiplication has little effect. We now study the effect of η , and γ_{max} by setting $\gamma_{min} = 1$. In Fig.4.3, we show the nonlinear mapping function $\gamma \otimes d$ by using adaptive gain control with $\gamma = \gamma(c)$ for the four combinations of η , and γ_{max} . We also compare these functions to that using a fixed gain $\gamma = \gamma_{max}$. We can see that while the fixed gain leads to saturation when the amplitude of the detail signal is large, the adaptive gain does not suffer from this problem.

For the adaptive gain control (dashed-line), a larger value of γ_{max} leads to a larger amplification of the amplitude of the detail signal around 1/2. This is evident when we compare the gradients of those dash lines

around 1/2. Recall that 1/2 is the zero (smallest amplitude, i.e. $d=1/2$, is equivalent to $|d|_0 = 0$) of the detailed signal. Therefore, large value γ_{max} helps enhance the minute details of the image. The role of the parameter η is to control the amplification behavior of the nonlinear mapping function when $|d|_0$ is relatively large. Comparing the two plots at the bottom row of Fig.4.3, we can see that when $\eta = 1$, the nonlinear mapping function is close to saturation when $|d|_0$ is large. As such, the setting of $\gamma_{max} = 5$ and $\eta = 1$ (bottom right) is better than $\gamma_{max} = 3$ and $\eta = 1$ (bottom left). We also observe that when γ_{max} is relatively small such as $\gamma_{max} = 3$ the effect of the adaptive gain control is not significant.

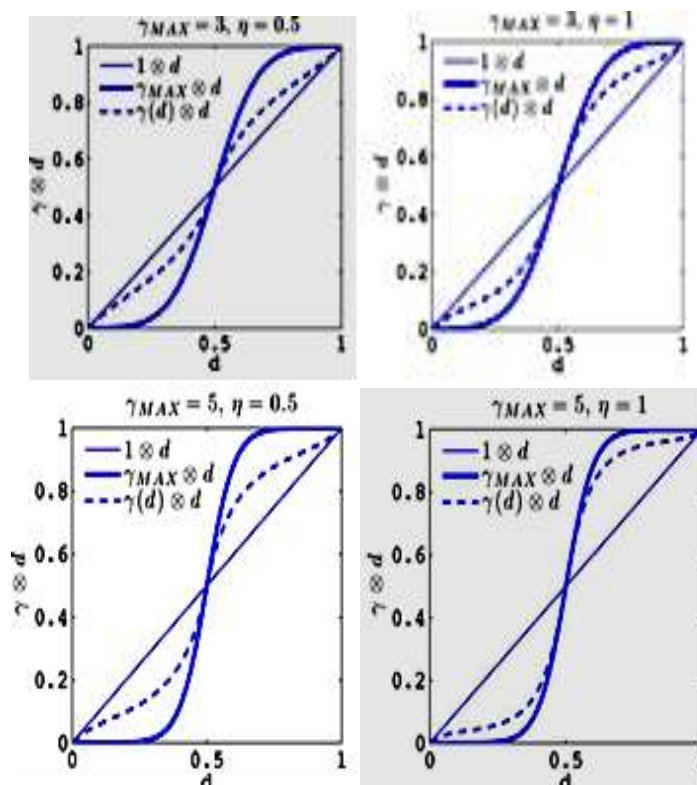

Fig.4.3: Illustrations of adaptive gain control for four combinations of η and γ_{max}

This is also observed in our experiment with images. As such, adaptive gain control is useful when a relatively large γ_{max} must be used to enhance the minute details and to avoid the saturation effect.

4.4 Contrast Enhancement of the Root Signal

Adaptive histogram equalization (AHE) is a computer image processing technique used to improve contrast in images. It differs from ordinary histogram equalization in the respect that the adaptive method computes several histograms, each corresponding to a distinct section of the image, and uses them to redistribute the lightness values of the image. It is therefore suitable for improving the local contrast of an image and bringing out more detail.

Ordinary histogram equalization uses the same transformation derived from the image histogram to transform all pixels. This works well when the distribution of pixel values is similar throughout the image. However, when the image contains regions that are significantly lighter or darker than most of the image, the contrast in those regions will not be sufficiently enhanced.

V. RESULTS AND DISCUSSIONS

All test images are downloaded from the Internet: www.cs.huji.ac.il/~danix/epd/. I use the canyon image called: Hunt's Mesa (shown in Fig.5.1) to study the proposed algorithms. I first show the effects of the two contributing parts: contrast enhancement and detail enhancement. Contrast enhancement by adaptive histogram equalization does remove the haze-like effect of the original image and contrast of the cloud is also greatly enhanced.



Fig.5.1: Comparison of individual effects of contrast enhancement and detail enhancement. Images from left to right: original, only with detail enhancement, only with contrast enhancement, and with both enhancements.

However, the minute details on the rocks are not sharpened. On the other hand, only using detail enhancement does sharpen the image but does not improve the overall contrast. When I combine both operations both contrast and details are improved.

5.1 Results For Grayscale Image

5.1.1 Results Of Cum



Fig.5.2: Original gray scale image **Fig.5.3:** Result of CUM

Fig 5.2 is the original image, and Fig 5.3 is the result of classical unsharp masking algorithm, it exhibit halo effect at the edges of the image, it is marked by the red ellipse, and it is a drawback of classical unsharp masking algorithm.

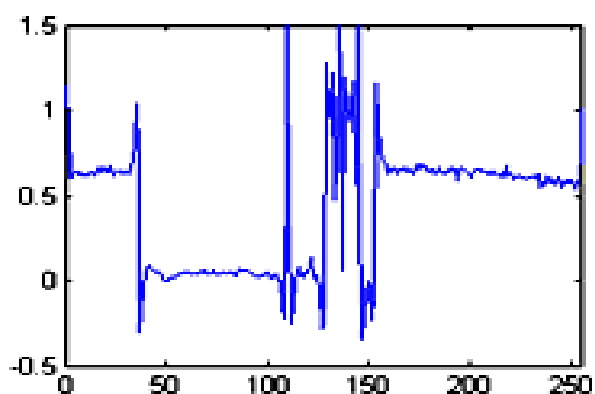

Fig.5.4: 100th row gray level profile of CUM resultant image

Fig 5.4 is the 100th row gray level profile of resultant image of classical unsharp masking algorithm. It exhibit out of range problem, that is the range of image taken for processing is [0, 1], but the resultant image exceeds this range.

The size of the image is 256 X 256, means 256 rows and 256 columns among these one of the column or row gray level profile can choose to exhibit the out of range problem, here all the pixels are not suffer with out of range problem, so there is no guaranty to exhibit out of range problem for all rows and columns, so choose appropriate column or row to exhibit out of range problem. In this case 100th row is chosen to show the out of range problem.

5.1.2 Results Of Gum



Fig.5.5: Result of GUM

Fig.5.5 is the result of generalized unsharp masking algorithm, it exhibit the reduced halo_effect , sharpness and contrast are enhanced simultaneously .

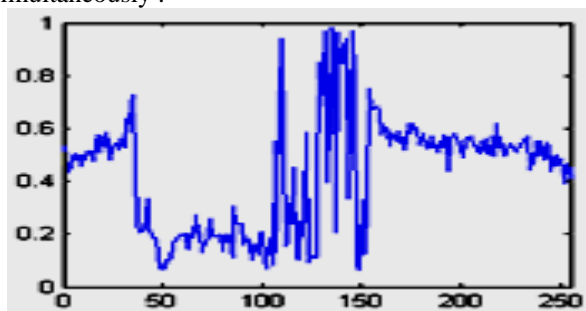

Fig.5.6: 100th row gray level profile of GUM resultant image

Fig.5.6 shows the 100th row gray level profile(it is same row for classical unsharp masking to compare out of range problem) of generalized unsharp masking resultant image,it exhibit the solved out of range problem, the range is in between [0 ,1]

5.2 Results For Color Images

5.2.1 Results Of Cum



Fig.5.7: Original color image



Fig.5.8: Result of CUM

Fig.5.7 is the original image and Fig.5.8 is the result of classical unsharp masking algorithm, it exhibit halo effect at the edges of the image, it is marked by the red ellipse, and it is a drawback of classical unsharp masking algorithm.

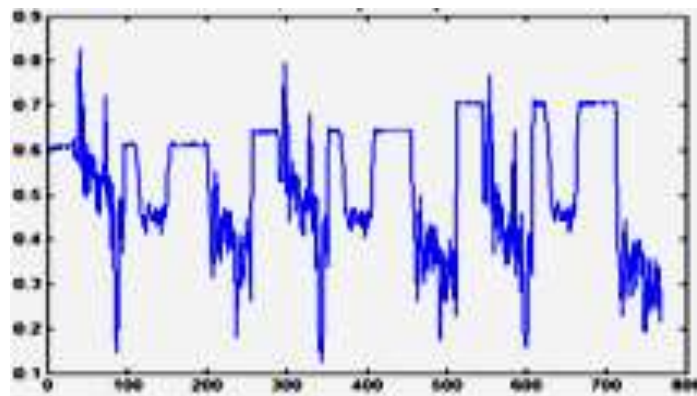

Fig.5.9:100th row gray level profile of original image

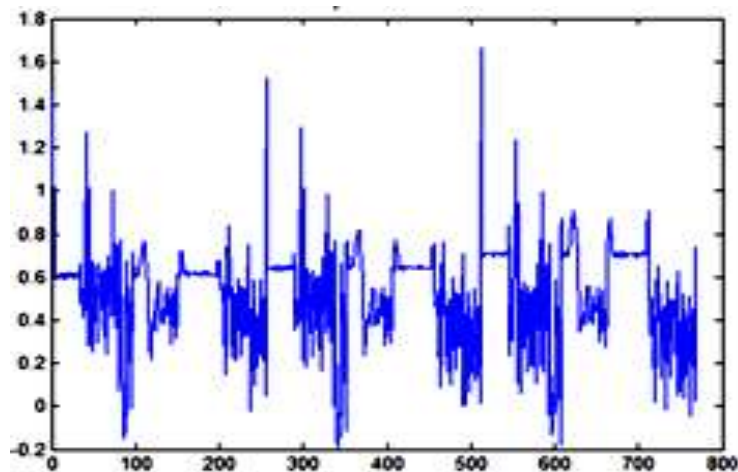

Fig.5.10:100th row gray level profile of CUM resultant image

Fig.5.9 and 5.10 are the 100th row gray level profile of original and resultant image of classical unsharp masking algorithm. It exhibit out of range problem, that is the range of image taken for processing is [0, 1], but the resultant image exceeds this range.

5.2.3 Results Of Gum



Fig.5.11: Result of GUM

Fig.5.11 is the result of generalized unsharp masking algorithm, it exhibit the reduced halo effect , sharpness and contrast are enhanced simultaneously.

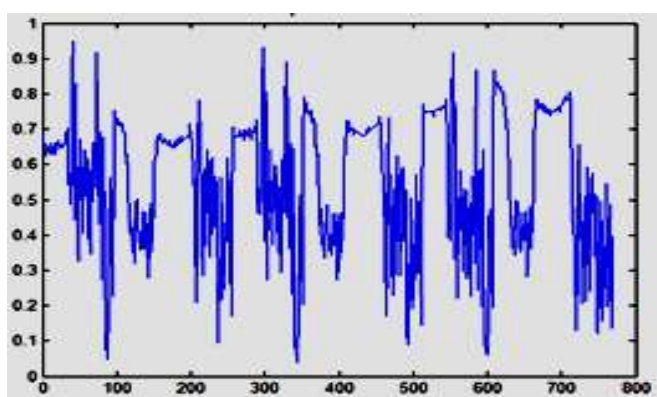

Fig 5.12: 100th row gray level profile of GUM resultant image

Fig.5.12 shows the 100th row gray level profile(it is same row for classical unsharp masking to compare out of range problem) of generalized unsharp masking resultant image,it exhibit the solved out of range problem, the range is in between [0 ,1].

VI. CONCLUSION

In this paper, I use an exploratory data model as a unified framework for developing generalized unsharp masking algorithms. Using this framework, I propose a new algorithm to address three issues associated with classical unsharp masking algorithms: 1) simultaneously enhancing contrast and sharpness by means of individual treatment of the model component and the residual, 2) reducing the halo-effect by means of an edge-preserving filter, and 3) eliminating the rescaling process by means of log-ratio and tangent operations.

I present a study of the log-ratio operations and their properties. In particular, we reveal a new connection between the Bregman divergence and the generalized linear systems (including the log-ratio, MHS and the LIP model). This connection not only provides us with a novel insight into the geometrical property of generalized linear systems, but also opens a new pathway to develop such systems. I present a new system called the tangent system which is based upon a specific Bregman divergence. Experimental results show that the proposed algorithm is able to significantly improve the contrast and sharpness of an image.

In the proposed algorithm, the user can adjust the two parameters controlling the contrast and sharpness to produce the desired results. This makes the proposed algorithm practically useful. Extensions of this work can be carried out in a number of directions. In this work, I only test the IMF as a computationally inexpensive edge preserving filter. It is expected that other more advanced edge preserving filters such as bilateral filter/non-local means filter, the least squares filters and wavelet based denoising can produce similar or even better results. The proposed algorithm can be easily extended into multiresolution processing. This will allow the user to have better control of the detail signal enhancement. For contrast enhancement, I only use adaptive histogram equalization. It is expected that using advanced algorithms such as recently published retinex and dehazing algorithm can improve the quality of enhancement. I do not consider the problem of avoiding enhancement of noise. This problem can be tackled by designing an edge preserving filter which is not sensitive to noise. The idea of the cubic filter can be useful. It can also be tackled by designing a smart adaptive gain control process

such that the gain for noise pixels is set to a small value. I have shown that the proposed system is for systematically solving the out-of-range problem.

BIBLIOGRAPHY

- [1]. G. Ramponi, "A cubic unsharp masking technique for contrast enhancement," *Signal Process.*, pp. 211–222, 1998.
- [2]. S. J. Ko and Y. H. Lee, "Center weighted median filters and their applications to image enhancement," *IEEE Trans. Circuits Syst.*, vol. 38, no. 9, pp. 984–993, Sep. 1991.
- [3]. M. Fischer, J. L. Paredes, and G. R. Arce, "Weighted median image sharpeners for the world wide web," *IEEE Trans. Image Process.*, vol. 11, no. 7, pp. 717–727, Jul. 2002.
- [4]. R. Lukac, B. Smolka, and K. N. Plataniotis, "Sharpening vector median filters," *Signal Process.*, vol. 87, pp. 2085–2099, 2007.
- [5]. A. Polesel, G. Ramponi, and V. Mathews, "Image enhancement via adaptive unsharp masking," *IEEE Trans. Image Process.*, vol. 9, no. 3, pp. 505–510, Mar. 2000.
- [6]. E. Peli, "Contrast in complex images," *J. Opt. Soc. Amer.*, vol. 7, no. 10, pp. 2032–2040, 1990.
- [7]. S. Pizer, E. Amburn, J. Austin, R. Cromartie, A. Geselowitz, T. Greer, B. Romeny, J. Zimmerman, and K. Zuiderveld, "Adaptive histogram equalization and its variations," *Comput. Vis. Graph. Image Process.*, vol. 39, no. 3, pp. 355–368, Sep. 1987.
- [8]. J. Stark, "Adaptive image contrast enhancement using generalizations of histogram equalization," *IEEE Trans. Image Process.*, vol. 9, no. 5, pp. 889–896, May 2000.
- [9]. E. Land and J. McCann, "Lightness and retinex theory," *J. Opt. Soc. Amer.*, vol. 61, no. 1, pp. 1–11, 1971.
- [10]. B. Funt, F. Ciurea, and J. McCann, "Retinex in MATLAB™," *J. Electron. Imag.*, pp. 48–57, Jan. 2004.
- [11]. M. Elad, "Retinex by two bilateral filters," in *Proc. Scale Space*, 2005, pp. 217–229.
- [12]. J. Zhang and S. Kamata, "Adaptive local contrast enhancement for the visualization of high dynamic range images," in *Proc. Int. Conf. Pattern Recognit.*, 2008, pp. 1–4.
- [13]. Z. Farbman, R. Fattal, D. Lischinski, and R. Szeliski, "Edge-preserving decompositions for multi-scale tone and detail manipulation," *ACM Trans. Graph.*, vol. 27, no. 3, pp. 1–10, Aug. 2008.